



Damayyan

PUTRA HEIGHTS

Home to Serenity and Family

Putra Heights welcomes a new freehold,
low-density residence.

Coming Soon

Home to Serenity and Family

Embrace family living in the heart of Putra Heights!

Our new low-density, freehold residences offer a tranquil escape from urban life. Embrace the calming atmosphere and cherish moments with your loved ones in this family-centric community.



Escape to Tranquil Living

Find serenity just a stone's throw away from the city, where you can escape the urban hustle and immerse in a calming, nature-inspired environment. Enjoy the convenience of excellent highway connections and LRT access within a mature township while staying close to your family in a warm, close-knit community.



Serene Nature Living for You



Freehold & low-density
(308 units only)



838-1,178 sq.ft. with 2-3 bedrooms



120m walk to Giant Hypermarket



350m walk to Putra Heights
Community Park



650m walk to
Putra Heights LRT Station



Live Within Convenience

In the heart of it all stands Damayan Residences, where conveniences are all around you. Whether it's the serene Community Park, the nearby Putra Heights LRT Station or the essential shopping at Giant and Jaya Grocer (The Glades Plaza), every element enhances your living experience.



Your Surrounding Adventures



Connectivity

- 650m Putra Heights LRT Station
- 1.5km ELITE Highway Putra Heights Interchange



Leisure

- 100m Putra Point Commercial Centre
- 120m Giant Hypermarket
- 350m Putra Heights Community Park
- 800m Putra Heights Mosque
- 1.0km Putra Heights Linear Park
- 3.0km The Glades Plaza



Education

- 250m Leo International
- 2.4km SK Putra Heights 2
- 2.8km IIUM Montessori
- 3.6km SMK Alam Megah 2
- 3.9km Kingsley International School
- 4.2km SK Taman Alam Megah
- 8.6km MAHSA University



Wellness

- 9.7km KPMC Puchong Specialist Centre
- 10.0km Columbia Asia Hospital Puchong
- 11.2km KPJ Selangor Specialist Hospital
- 12.4km Ramsay Sime Darby Health Care (SJMC)

Floor Plan

Type A

838 sq.ft.



2 Bedrooms



2 Bathrooms

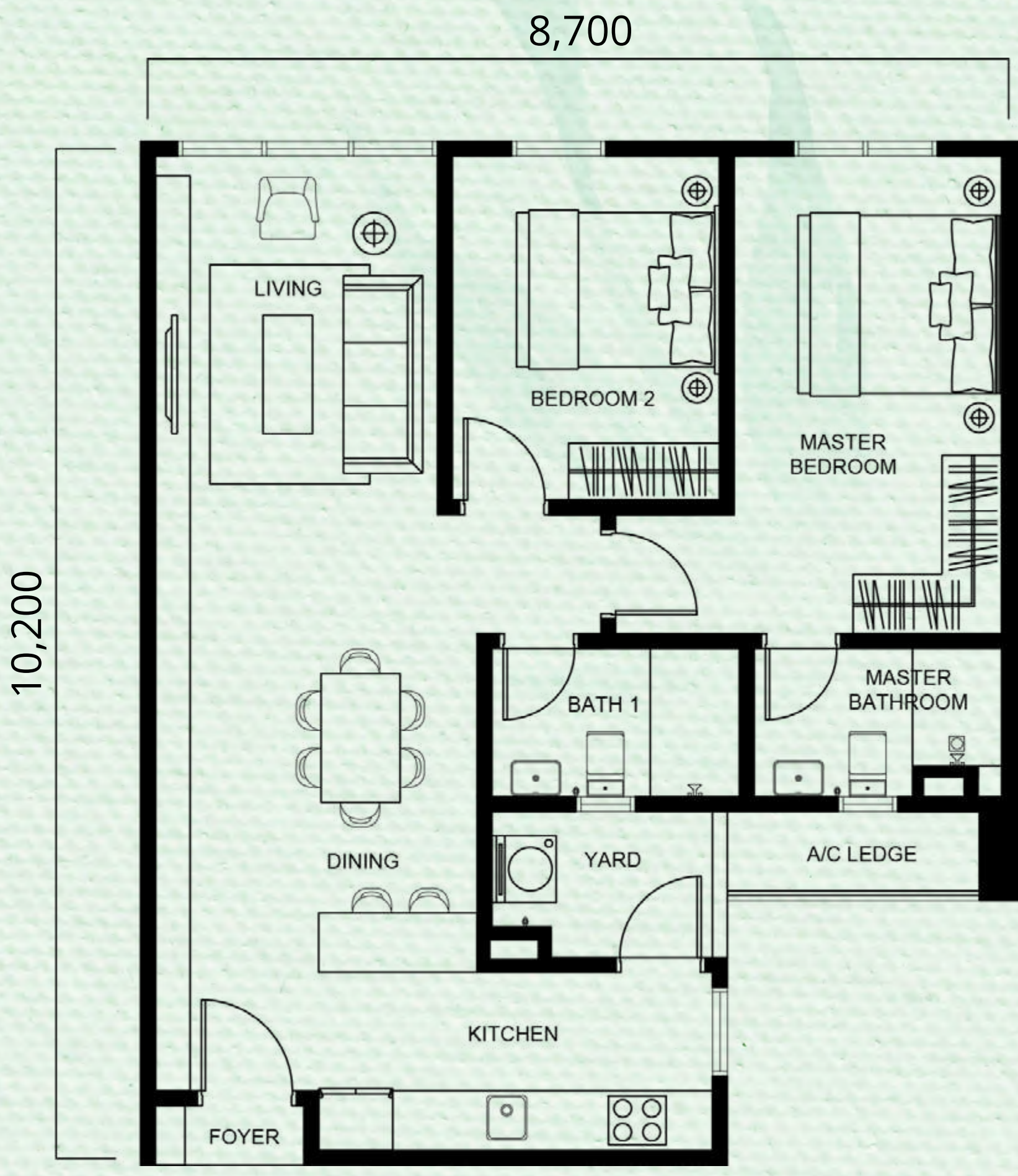
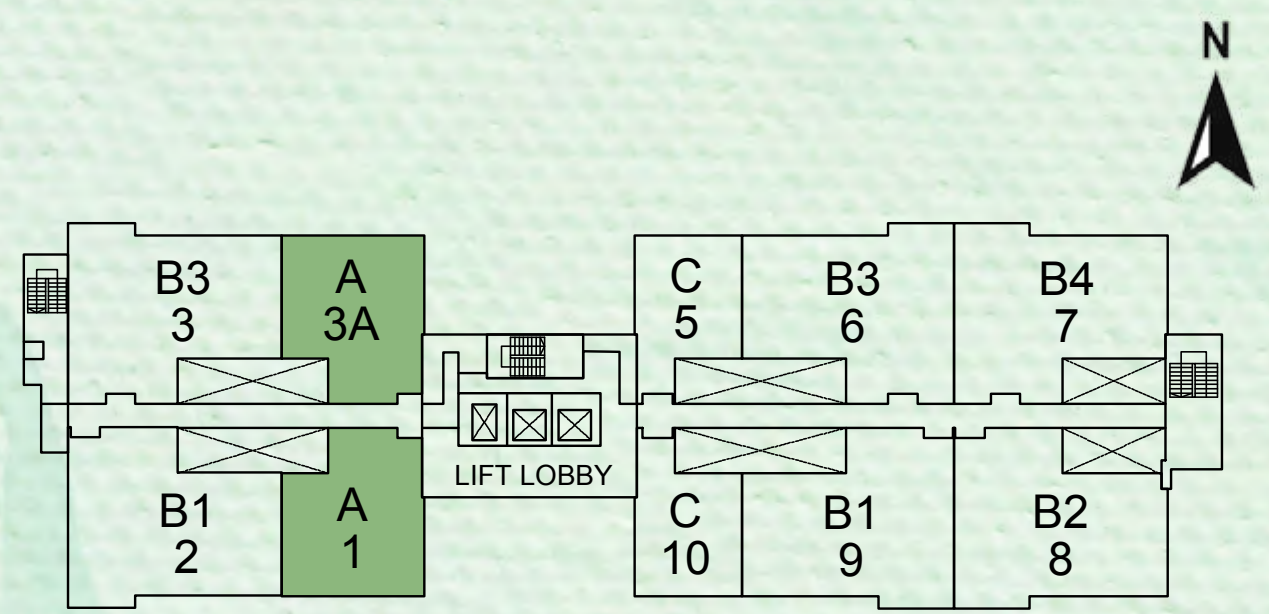

Floor Plan

Type B1

1,178 sq.ft.

 3 Bedrooms

 2 Bathrooms

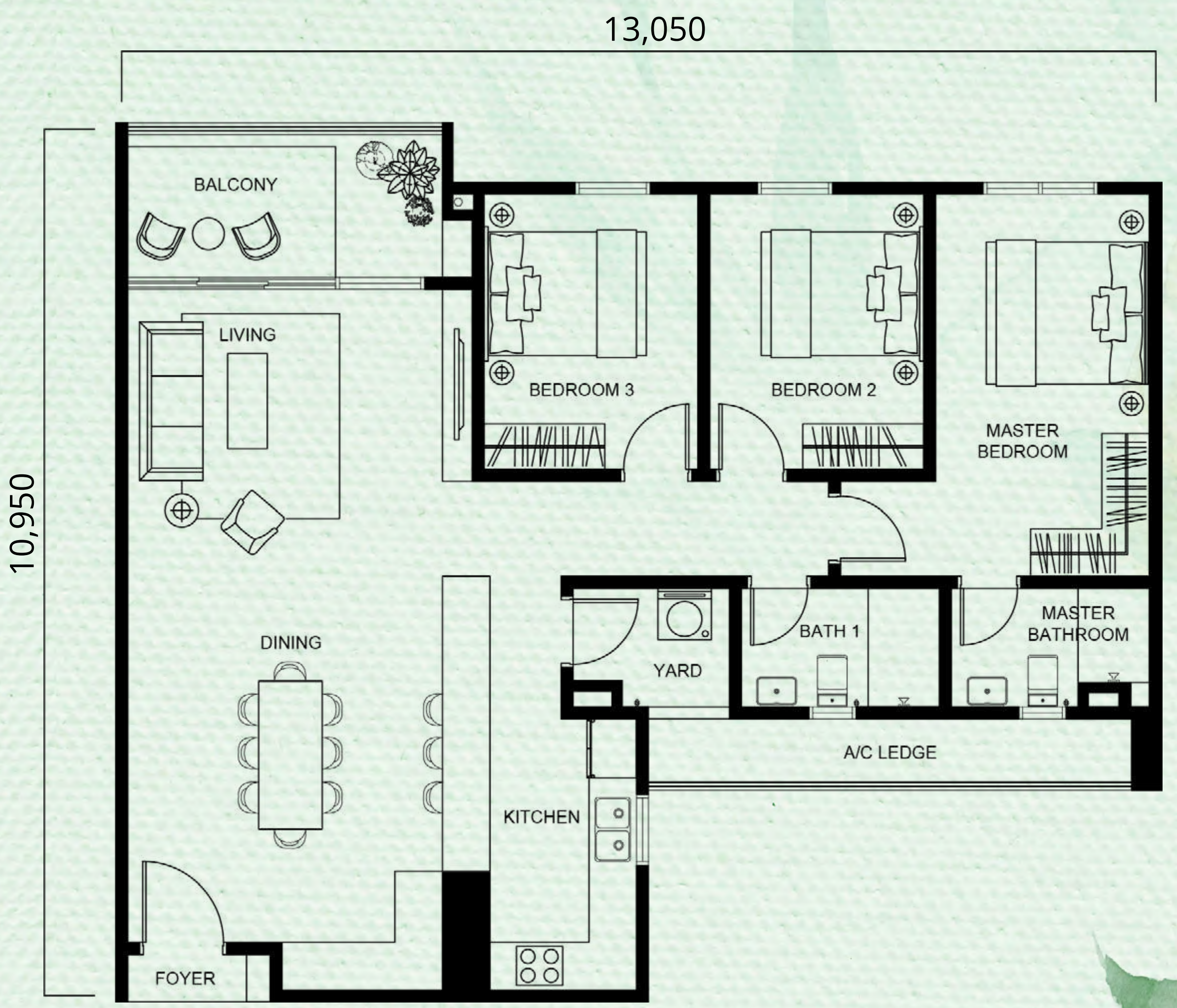
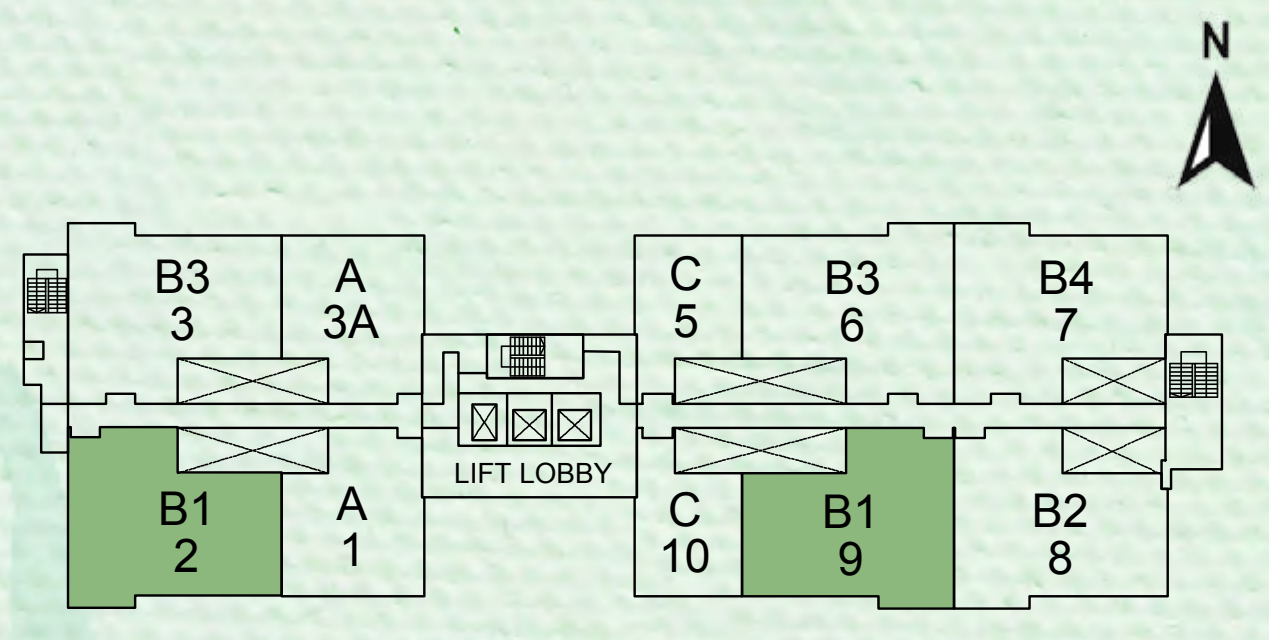

Floor Plan

Type B3

1,178 sq.ft.

 3 Bedrooms

 2 Bathrooms

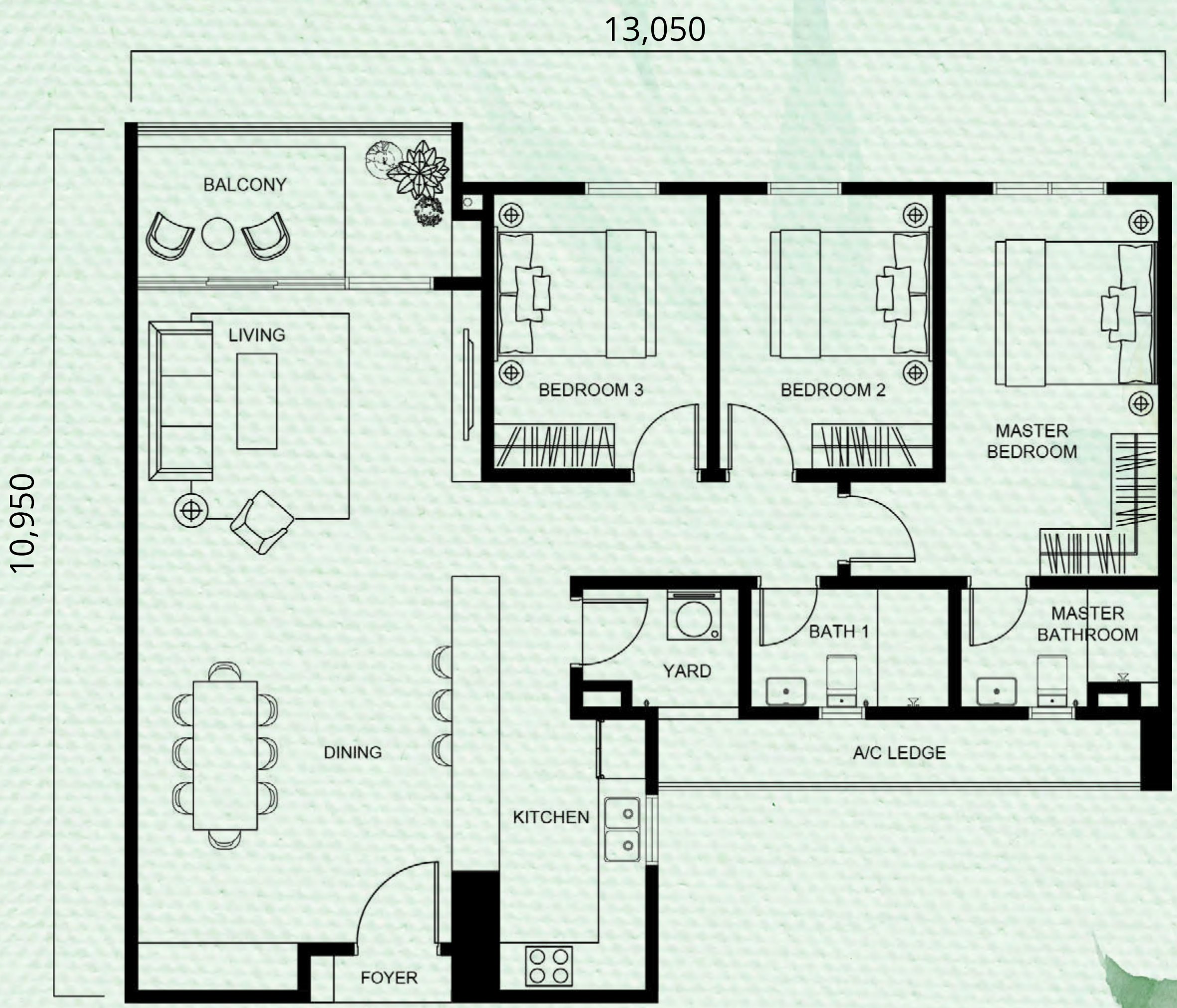
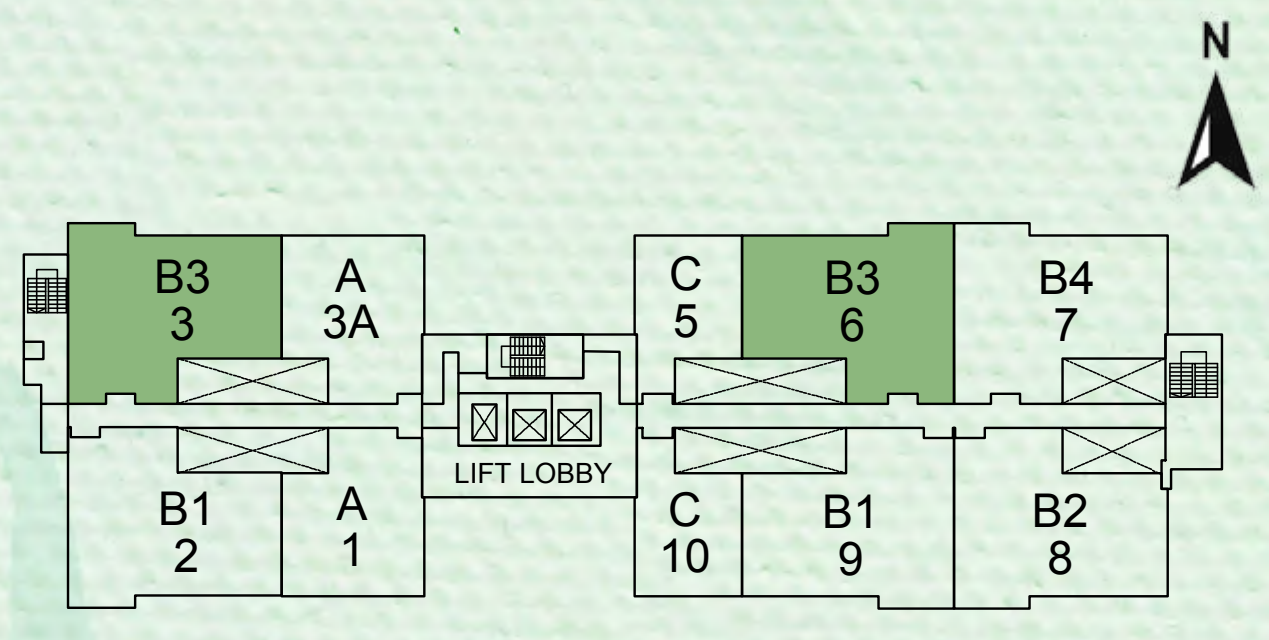

**Book your visit now and experience
our new show unit today!**

 **Putra Heights Sales Gallery**

Level 2, The Glades Plaza, Off Persiaran Putra Perdana,
Putra Heights, 47500, Subang Jaya, Selangor

Monday - Sunday: 9:30am - 6:00pm

03-5198 0888

Learn More At
damayan.com.my

PUTRA HEIGHTS



Property